

These drawings and specifications are the property of CAMBRIDGE TECHNOLOGY and shall not be reproduced, or copied, or used as the basis for the manufacture, or sale of apparatus without the written permission of CAMBRIDGE TECHNOLOGY, INC.

REVISION				
ECO	REV	DESCRIPTION	APPR	DATE
2805	B	-	----	
4089	C	17.3 WAS 17.4,	JZ	12-31-07

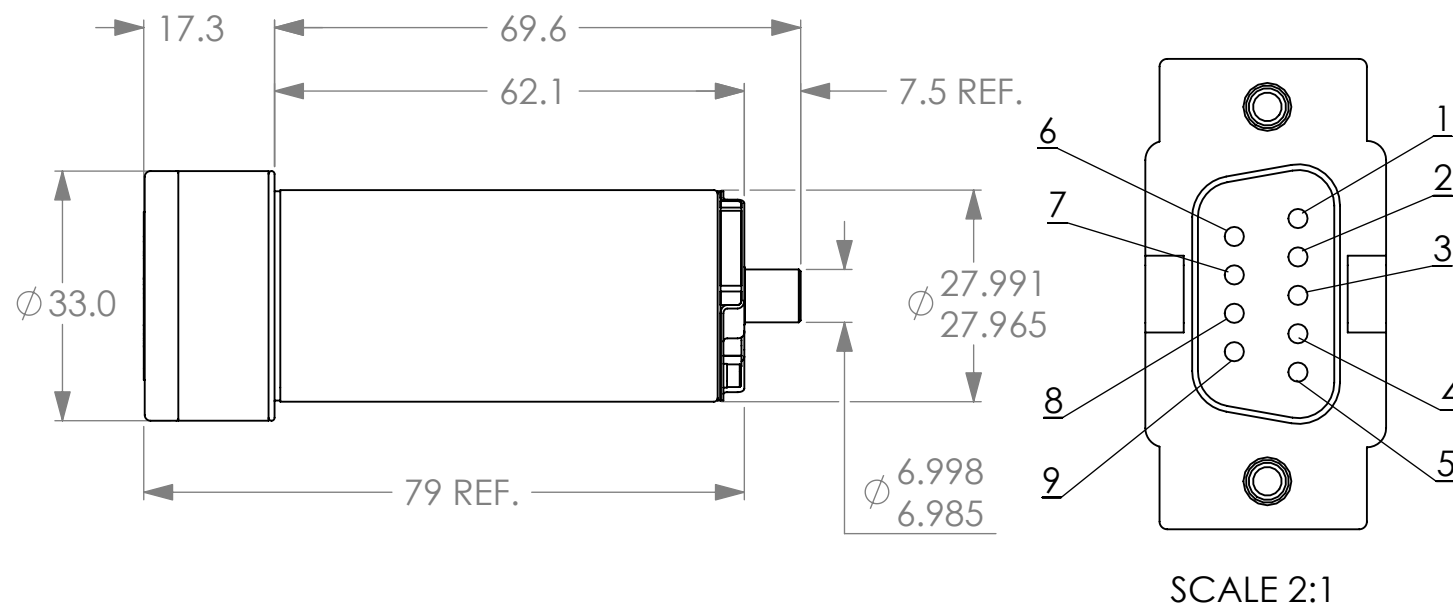
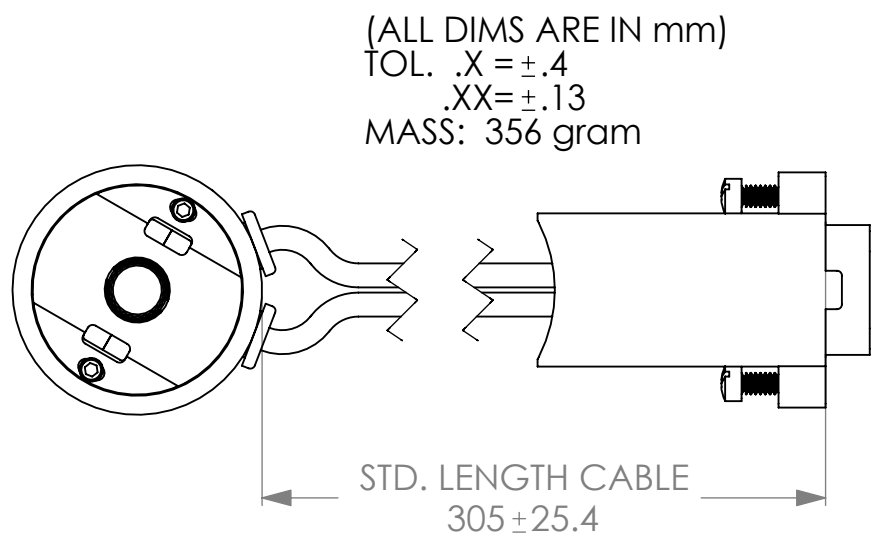

1	MOTOR +
2	MOTOR SHIELD
3	PD GND
4	DIODE COMMON
5	PD OUTPUT A
6	MOTOR -
7	PD SHIELD
8	AGC
9	PD OUTPUT B

		DRN		CAMBRIDGE TECHNOLOGY, INC. 25 HARTWELL AVENUE LEXINGTON, MA 02421-3102
		DES		
		CHK		
		ENG		
		APPR		
	SURFACE ROUGHNESS $\sqrt{63}$ BREAK ALL SHARP EDGES	PROJECTION		TITLE
	MATERIAL			6240H OUTLINE DRAWING
6240H	-	DRW. SIZE	A	
USED ON	-			SCALE 1:1 SHEET 1 OF 1