

These drawings and specifications are the property of CAMBRIDGE TECHNOLOGY and shall not be reproduced, or copied, or used as the basis for the manufacture, or sale of apparatus without the written permission of CAMBRIDGE TECHNOLOGY, INC.

REVISION				
ECO	REV	DESCRIPTION	APPR	DATE
2805	B	change dim to 59.5 from 59.6; change dim to 5.7 ref from 5.8 ref; add dim 54.1 over screw head; change dim to 74 REF. from 73.2; add mass 267 g	----	04/04/06
4089	C	19.6 WAS 19.8	JZ	12-31-07

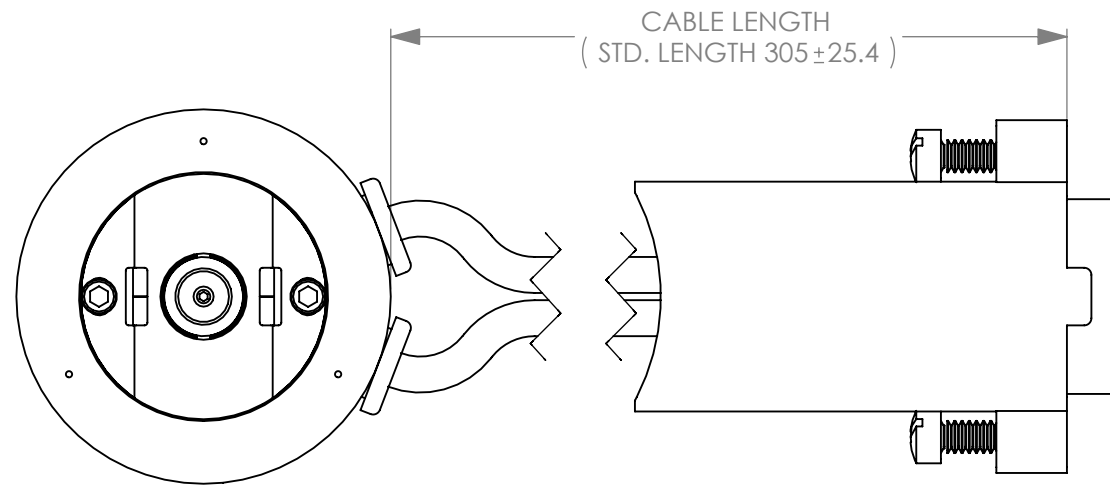

(ALL DIMS ARE IN mm)
 TOL. .X±.4
 .XX±.13
 MASS : 267 grams

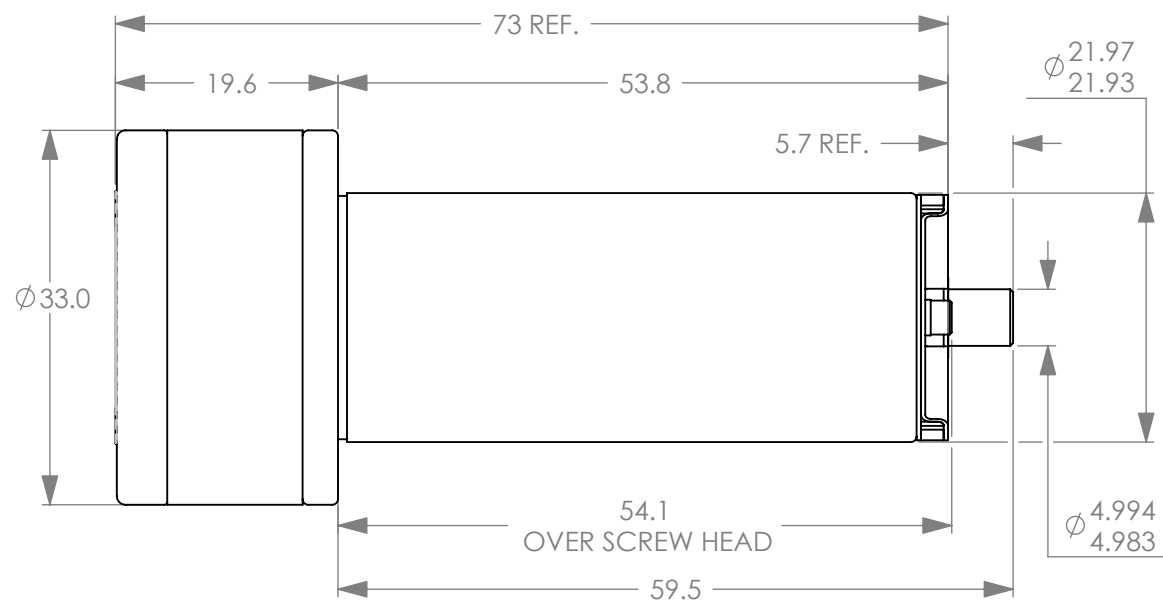
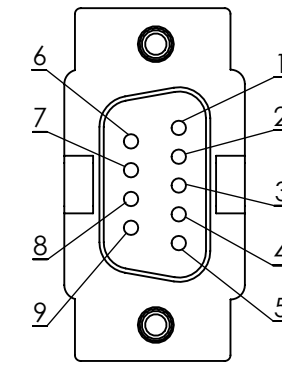

1	MOTOR +
2	MOTOR SHIELD
3	PD GND
4	DIODE COMMON
5	PD OUTPUT A
6	MOTOR -
7	PD SHIELD
8	AGC
9	PD OUTPUT B

		DRN		CAMBRIDGE TECHNOLOGY, INC. 25 HARTWELL AVENUE LEXINGTON, MA 02421-3102
		DES		
		CHK		
		ENG		
	SURFACE ROUGHNESS $63/\sqrt{\quad}$ BREAK ALL SHARP EDGES	APPR		TITLE
	MATERIAL -	PROJECTION		
6230H	FINISH -	DRW. SIZE	A	DRW. NO. D05999
USED ON				REVISION C
				SCALE 3:2
				SHEET 1 OF 1